

NOTE:
 DRYER CHAMBER TO BE BOLTED TO WASH CHAMBER WITH 1/4"-20 X 5/8" HEX HEAD STAINLESS STEEL SCREWS THRU (19) 11/32 DIA. MATCHING HOLES. USE FOAM TAPE (1" WIDE X .060 THICK) AS A GASKET TO SEAL THIS JOINT.

SINGLE POINT ELECTRICAL CONNECTION
 BLOWER MOTOR & ELECTRIC HEAT
 (3 PH ONLY)

ELECTRICAL SPECS	RATED AMPS	MINIMUM SUPPLY CIRCUIT CONDUCTOR AMPACITY	MAXIMUM PROTECTIVE DEVICE
208/60/3	34.2	45	45
240/60/3	30.7	40	40
380/60/3	17.8	25	25
480/60/3	15.7	20	20
600/60/3	12.6	20	20
200/50/3	33.0	45	45
380-415/50/3	17.8	25	25

CONNECTION INFORMATION
 (AFF = ABOVE FINISHED FLOOR)

LEGEND

- E7 ELECTRIC CONNECTION: KNOCKOUT MADE BY CUSTOMER, 1-1/8" CONDUIT HOLE, 61" AFF.
- P6 INDIRECT DRAIN-FLOOR SINK: BY OTHERS, 0" AFF. WHEN REQUIRED, INSTALL FLOOR SINK OUTSIDE THE PERIMETER OF THE DISHWASHER.
- P13 DRAIN CONNECTION IN DRYER TANK: 1" FPT.
- V1 VENT CONNECTION-ENTRANCE END: 4" WIDE x 16" LONG (INSIDE DIM.) WITH LOCKING TYPE DAMPER. 200 C.F.M.
- V2 VENT CONNECTION-DISCHARGE END: 4" WIDE x 16" LONG (INSIDE DIM.) WITH LOCKING TYPE DAMPER. 400 C.F.M.

REFER TO BLOWER DRYER SPECIFICATION SHEETS FOR TABLE CONNECTION INFO

NOTE:
 REFER TO DISHWASHER DWG OF MACHINE USED FOR VENT LOCATION AT ENTRANCE END.

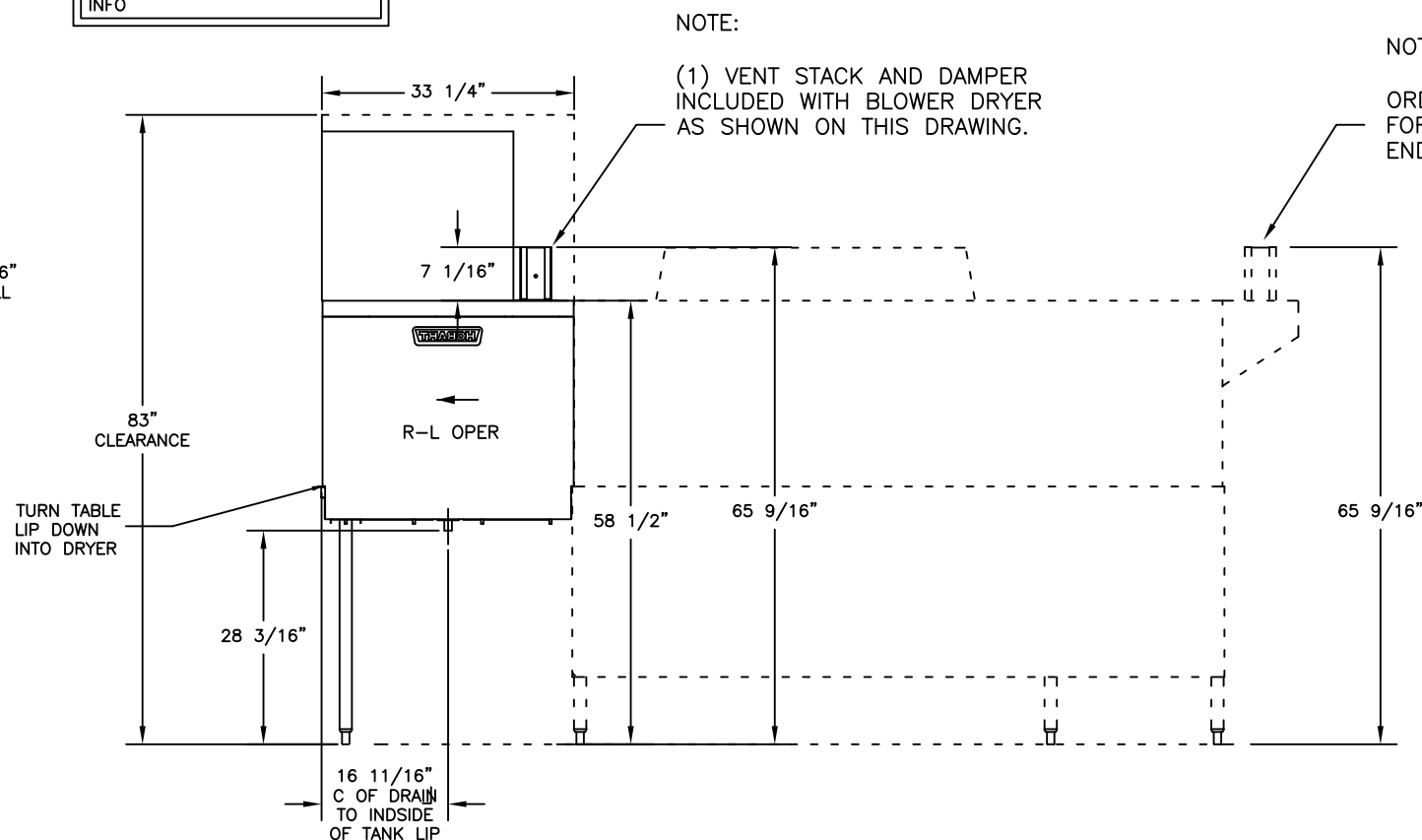
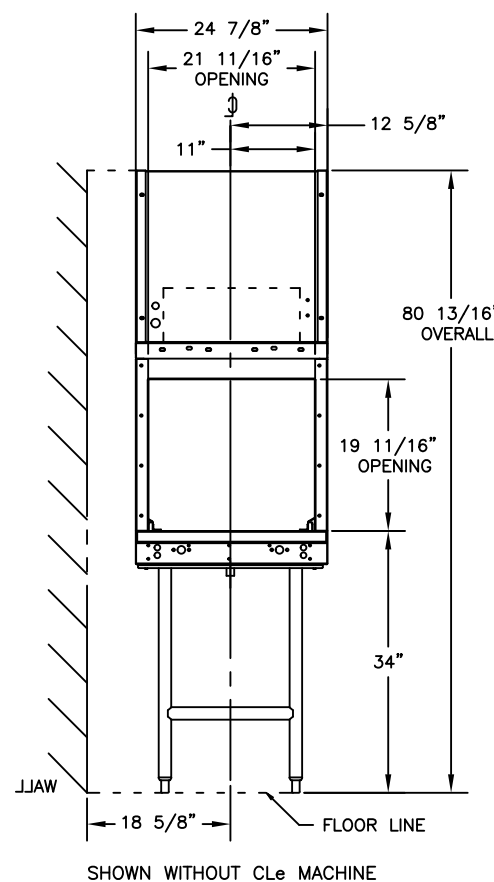

NOTE:
 (1) VENT STACK AND DAMPER INCLUDED WITH BLOWER DRYER AS SHOWN ON THIS DRAWING.

NOTE:
 ORDER (1) (OPTIONAL) VENT HOOD FOR CONNECTION AT THE ENTRANCE END OF DISHWASHER.

NOTE:
 THIS DRAWING IS SUPPLIED AS A REFERENCE FOR CONNECTION INFORMATION ONLY. IT WILL NOT BE UTILIZED FOR MANUFACTURING OF UNIT.
 CUSTOMER SERVICE, IN TROY, OHIO, MUST BE NOTIFIED OF ANY CHANGES.



ELECTRICAL AND GROUNDING CONNECTIONS MUST COMPLY WITH THE APPLICABLE PORTIONS OF THE NATIONAL ELECTRICAL CODE AND/OR OTHER LOCAL ELECTRICAL CODES.

PLUMBING CONNECTIONS MUST COMPLY WITH APPLICABLE SANITARY, SAFETY, AND PLUMBING CODES.

CAUTION:
 CERTAIN MATERIALS INCLUDING SILVER, ALUMINUM, AND PEWTER ARE ATTACKED BY SODIUM HYPOCHLORITE (LIQUID BLEACH).

H.O.#
 PROJECT#
 QUOTE#

REV	DESCRIPTION	DATE	INIT.
NAME:	SALES DRAWING		
MODEL:	BLOWER DRYER, ELECTRIC HEAT		
DIRECTION:	R-L	DATE:	1/19/17
DRAWN BY:		SIZE:	DRAWING NO.
HOBART		Y	
		SHEET 1 OF 1	REV. 1